

WB TYPE F MAGNETIC DRUM BRAKES

Type QW and Type LC
Brake Rectifiers

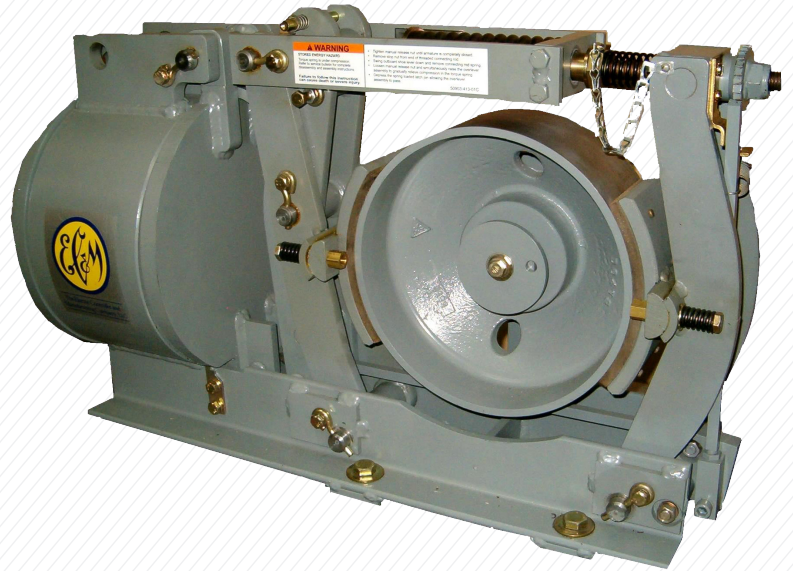

CONTENTS

Description	Page
General Information.....	3
Technical Specifications.....	4-8
Series Brakes.....	4-5
Shunt Brakes and Resistors.....	6
Rectifier Operated Brakes with Type QW Rectifier Controllers.....	7
Rectifier Operated Brake with Type LC Rectifiers.....	8
Type F Brake Modifications.....	8
Brake Required Ordering Information.....	9
Brake Wheel Required Ordering Information and Application Data.....	9-10
Brake and Brake Wheel Ratings Data.....	10
Brake and Brake Wheel Weights.....	11
Brake Torque Selection and Wheel Thermal Capability.....	11-12
Elementary Wiring Diagrams for Standard Brake Circuits.....	13
Brake Dimensions.....	14
Brake Rectifier Controller and Brake Rectifier Dimensions.....	15

Class 5010 | DC Magnetic Drum Brakes

GENERAL INFORMATION



**Class 5010 Type F1325
13" Brake**



**Class 5010 Type F3004, 30" Brake
With Optional Conduit Box
(Form B)**



**Class 5010 Type QW116V81
Rectifier Controller**

Class 5010 DC Magnetic Drum Brakes

Class 5010 Type F brakes are spring set, electrically released, drum type friction brakes used with either AC or DC motors

- Designed to meet AIST Technical Report 11 and NEMA standards
- Corrosion resistant pins standard on all brake sizes
- Grease fittings standard on 19", 23" and 30" brake sizes
- Optional self-adjuster compensates for lining wear

Series Brakes

- Used as holding brakes on DC series motor drives
- Used on crane hoists, mill drives and transfer cars
- Operating coil connected in series with motor armature
- Releases and sets in response to motor current

Standard Shunt Brakes

- Used as holding or stopping brakes on DC reversing drives such as crane bridges or trolleys and mill auxiliary drives
- Brake coil and protective resistor rated for line voltage

High Speed Shunt Brakes

- Used as stopping brakes on DC reversing drives
- Faster set and release times than standard shunt brake operation
- Brake coil and protective resistor rated for line voltage, relay controls the amount of resistance in circuit

Rectifier Operated Brakes

- DC shunt brake designed to operate from a brake rectifier controller
- Used as holding or stopping brake on AC applications such as cranes, conveyors, or movable bridges
- Type QW provides high speed operation similar to DC high speed shunt brake

Type F Mill Duty Brake Technical Specifications

- 8" to 30" Mill duty drum brakes
- Torque range available from 35 - 9000 lb-ft.
- Brake lining friction coefficient $\mu = 0.46$
- AIST TR-11 mounting dimensions

Brake Type	Connection	Brake Coil Duty Rating	Typical Use	Minimum Current or Voltage required for Release at Maximum Rated Torque
Series	In series with 1/2-hour rated DC Series Motor	1/2-hr duty, equivalent to 1 minute ON / 2 minutes OFF	Holding brake	40% of motor full load current. Brake will set when current is reduced to 10% of motor full load current
	In series with 1-hour rated DC Series Motor	1-hr duty, equivalent to 1 minute ON / 1 minute OFF		
Standard shunt	Across line voltage with a resistor wired in series with the coil	1-hr duty, equivalent to 1 minute ON / 1 minute OFF	Holding or Stopping brake	80% of nominal line voltage
		8-hr continuous duty	Holding brake	
AC rectifier operated	Used with brake rectifier controller	Any Duty	Holding or Stopping brake	80% of nominal line voltage
High-speed shunt	Across line voltage with resistor and protective relay wired in series with coil	Any Duty	Stopping brake	80% of nominal line voltage

Class 5010 | DC Magnetic Drum Brakes

TECHNICAL SPECIFICATIONS

Series Brake Technical Specification

- Brake Wheel Size must be selected based on motor torque and application before selecting the Brake Type below
- Consult Crane Control Application Data; DC Motor Data before making Brake Type (operating coil HP) selections below

Series Brakes					
Brake Size (inches)	Maximum Torque (ft-lb)		Maximum HP Rating at 230 VDC ■		Type
	1/2 Hour	1 Hour	1/2 Hour	1 Hour	
8	100	65	4.5+	3.5+	F0809
			6	4.5	F0808
			7	5.5	F0807
			10	8	F0806
			13	10.5	F0805
			17	14	F0804
			22	18	F0803 ▲
			26.5	21	F0802 ▲
			37.5	30	F0801 ▲
10	200	130	5	4	F1031
			7	5	F1028
			8.5	7	F1030
			11.5	8.5	F1027
			14	11	F1026
			17	14	F1029
			23	18	F1025
			30	23	F1024 ▲
			38	30	F1023 ▲
			50	39	F1022 ▲
			61	48	F1021 ▲
13	550	365	7	5	F1332
			9	7	F1331
			12	9	F1328
			15	12	F1327
			19	15	F1326
			24	19	F1330
			30.5	24	F1325
			39	31	F1324 ▲
			49.5	40	F1323 ▲
			63	50	F1329 ▲
			80	64	F1321 ▲
100	80	F1322 ▲			
16	1000	650	8	6	F1633
			11	8	F1632
			14	11	F1630
			18	14	F1629
			22	17.5	F1628
			29	22	F1627
			37	29	F1626
			47	36	F1624
			60	46	F1625
			77	59	F1623
			96	76	F1622 ▲
122	95	F1621 ▲			

■ Other coils are available if required, consult factory for information

▲ Consult factory before applying. Horsepower listed exceeds the torque rating of the brake

Class 5010 | DC Magnetic Drum Brakes

Series Brake Technical Specification

- Brake Wheel Size must be selected based on motor torque and application before selecting the Brake Type below
- Consult Application Data before making Brake Type (operating coil HP) selections below

Series Brakes					
Brake Size (inches)	Maximum Torque (ft-lb)		Maximum HP Rating at 230 VDC ■		Type
	1/2 Hour	1 Hour	1/2 Hour	1 Hour	
19	2000	1300	23	17	F1913
			29	22	F1912
			36	28	F1911
			47	35	F1910
			61	46	F1909
			78	59	F1908
			97	76	F1907
			120	90	F1906
			155	116	F1905
			178	134	F1904 ▲
			200	150	F1903 ▲
			230	174	F1902 ▲
			320	245	F1901 ▲
23	4000	2600	27.5	20	F2332
			36.5	26	F2331
			44	34	F2330
			56.5	43	F2329
			72	55	F2328
			90	71	F2327
			102	80	F2326
			117	90	F2325
			160	127	F2324
			180	142	F2336
			206	162	F2323
			235	185	F2335
			320	252	F2322 ▲
365	290	F2321 ▲			
30	9000	6000	100	77	F3009
			155	115	F3008
			200	150	F3007
			230	175	F3006
			300	230	F3005
			380	290	F3004
			410	315	F3003
			505	390	F3002
580	445	F3001 ▲			

■ Other coils are available if required, consult factory for information

▲ Consult factory before applying. Horsepower listed exceeds the torque rating of the brake

Class 5010 | DC Magnetic Drum Brakes

Shunt Brake Technical Specification

Shunt Brakes must be used with the dropping resistor specified below for standard DC shunt brake applications or with resistor and relay for high speed shunt brake applications. See Tables below

Shunt Brakes

Brake Size (inches)	Maximum Torque (ft-lb)		Type
	1/2 Hour	8 Hour	
8	100	65	F0857
10	200	130	F1077
13	550	400	F1375
16	1000	750	F1674
19	2000	1500	F1959
23	4000	3000	F2374
30	9000	6750	F3051

Shunt Brake Resistors for Standard DC Shunt Brakes

VDC	Brake Size (inches)	1-Hour ▲		8-Hour Δ	
		Open Type	Enclosed Type	Open Type	Enclosed Type
230	8	RO125	RG125	RO126	RG126
	10	RO105	RG105	RO128	RG128
	13	RO106	RG106	RO111	RG111
	16	RO106	RG106	RO109	RG109
	19	RO132	RG132	RO146	RG146
	23	RO136	RG136	RO138	RG138

▲ 1-Hour service is used on a crane when the brake sets every time the master switch is moved to the OFF point, i.e. intermittent service

Δ 8 Hour service is used when the brake stays released for an extended time or continuously. For example, the brake may stay released during an entire 8-hour shift while the crane is powered

Shunt Brake Resistors and Relays for High-Speed DC Shunt Brakes

VDC	Brake Size (inches)	Resistors		Relays
		Open Type	Enclosed Type	Class / Type / Form
230	8	RO127	RG127	7001 KFO F08
	10	RO119	RG119	7001 KFO F10
	13	RO148	RG148	7001 KFO F13
	16	RO126	RG126	7001 KFO F16
	19	RO148	RG148	7001 KFO F19
	23	RO116	RG116	7001 KFO F23
	30	51283-411	Consult Factory	7001 KIO11 F30 ◇

◇ 30" high-speed brake operation also requires 1- Class 7004 Type MXDO1 230V DC contactor

Class 5010 | DC Magnetic Drum Brakes

Rectifier Operated Brake Technical Specification

Rectifier operated brakes are for use on AC systems. All require use with either a Class 5010 Type QW or Type LC Brake Rectifier, both brake and rectifier selected for the system voltage and application. Brake selection of Type numbers depends upon the Type Number of rectifier selected.

Class 5010 Brake and Type QW Rectifier Ordering Information

Rectifier selection to indicate Class 5010 / Type / Voltage Code

Brakes for Operation with Class 5010 Type QW Brake Rectifier Controllers

Brake Size (inches)	Maximum Torque (ft-lb) Any Duty	Single Brake	Dual Brakes (Coils wired in series)
		Type ■	Type ■
8	100	F0853	F0851
10	200	F1072	F1070
13	550	F1370	F1385
16	1000	F1670	F1686
19	2000	F1954	F1951
23	4000	F2383	F2384
30	9000	Consult Factory	Consult Factory

■ Must be used with EC&M Type QW Brake Rectifier Controllers

Class 5010 Type QW Brake Rectifier Controllers (for all applications)

The Class 5010 Type QW Brake Rectifier Controllers are designed specifically for use with EC&M Class 5010 Type F Rectifier operated brakes. When used together, the brake and rectifier system is suitable for all AC powered brake applications. Converting AC line power to DC, the Type QW Brake controllers provide a high-speed forcing circuit to provide optimum operation of the Type F brake(s) for quick release and quick set at any torque. The standard controller includes

- Fused Transformer, 120VAC secondary
- 3-pole contactor
- Full wave rectifier with suppressor
- Class 7001 Type K DC current sensing relay
- Set of forcing resistors

Class 5010 Type QW Brake Rectifier Controllers

Brake Size (inches)	NEMA Type 3R Outdoor Enclosure		Voltage Codes	
	Single Brake	Dual Brakes (Coils wired in series)	VAC, 60HZ	Code
	Type	Type		
8	QW108	QW208	460	V81
10	QW110	QW210		
13	QW113	QW213		
16	QW116	QW216	380	V95
19	QW119	QW219		
23	QW123	QW223	230	V80
30	Consult Factory	Consult Factory		
			Special	Consult factory

Class 5010 | DC Magnetic Drum Brakes

Class 5010 Brake and Type LC Rectifier Technical Specification

Rectifier selection to indicate Class 5010 / Type / Voltage Code

Brakes for Operation with Class 5010 Type LC Brake Rectifiers

Brake Size (inches)	Maximum Torque (ft-lb) Any Duty	Single Brake	Dual Brakes (Coils wired in series)
		Type	Type
8	100	F0858	F0855
10	200	F1077	F1074
13	550	F1375	---

Class 5010 Type LC Brake Rectifiers (for travel motions only, Type F, 8", 10", 13" Brakes only)

The Class 5010 Type LC Brake Rectifiers are suitable for travel motions only on AC powered brake applications, converting AC line power to DC, for use with the EC&M rectifier operated brakes from the table above. The unit was designed for application where high speed forcing circuits, and high-speed brake operations are not required (e.g. for Variable Frequency Drive applications for travel motions). The standard controller includes:

- Fused Transformer, 120VAC secondary
- 3-pole contactor
- Full wave rectifier with suppressor

Class 5010 Type LC Brake Rectifiers

Brake Size (inches)	NEMA Type 3R Outdoor Enclosure		Voltage Codes	
	Single Brake	Dual Brakes (Coils wired in series)	VAC, 60HZ	Code
	Type	Type		
8	LC108	LC208	460	V81
10	LC110	LC210	230	V80
13	LC113	---	Special	Consult factory

TYPE F BRAKE MODIFICATIONS

Form	● Form Available for Brake	Brake Size (inches)						
		8	10	13	16	19	23	30
B - Conduit Connection Box		●	●	●	●	●	●	●
E1 - NEMA 3R Enclosure with Right Hand Slot ■		●	●	●	●	●	●	N/A
E2 - NEMA 3R Enclosure with Left Hand Slot ■		●	●	●	●	●	●	N/A
E3 - NEMA 3R Enclosure with Double Slot ■		●	●	●	●	●	●	N/A
H - Half Torque Spring		●	●	●	●	●	●	N/A
K1 - Aux Contacts via Limit Switch, Right Side Mounted ■		●	●	●	●	●	●	●
K2 - Aux Contacts via Limit Switch, Left Side Mounted ■		●	●	●	●	●	●	●
M - Grease Fittings ▼		●	●	●	●	STD	STD	STD
P - Dust Shield		●	●	●	●	●	●	N/A
R1 - Manual Release Lever, Right Side Mounted ■		●	●	●	●	●	●	N/A
R2 - Manual Release Lever, Left Side Mounted ■		●	●	●	●	●	●	N/A
S - Self-Adjuster		●	●	●	●	●	●	N/A
W - Wall (Vertical) Mounting		●	●	●	●	●	●	N/A

■ Right or Left side is defined as viewed standing at the coil end of the brake, facing the backplate. See Approximate Dimensions, pg.14

▼ Form M is recommended for brakes used outdoors or used indoors in the presence of high humidity, condensation or corrosive gases, and for use with Forms E1, E2, or E3

Class 5010 | DC Magnetic Drum Brakes

BRAKE ORDERING INFORMATION

Ordering Information Required

When Class & Type cannot be specified:

- Motor Horsepower / kW and RPM
- Motor Application (Hoist, Bridge, Trolley, other)
- Series, Shunt, or Rectifier Operated
- If Rectifier operated, advise Motor Controller type: VFD or Constant Potential (contactor controlled)
- Modifications
- With or Without Wheel (For With Wheel, see page 9 for wheel data required for order entry)

DC Magnetic Brake by Class, Type and Form

- Class / Type / Form (for modifications, specify Form letters)
- With or Without Wheel (For with Wheel, see page 9 for wheel data required for order entry)
- System Voltage if different from standard

Shunt Brake Resistors

- For use with standard shunt brake: Class / Type
- For use with high-speed shunt brake: Class / Type / Form

Brake Rectifiers:

- Controller Type: VFD or Constant Potential (contactor controlled)
- Class / Type / Voltage code (or system voltage and frequency)
- Brake size or Brake Type number to be used with the rectifier

Brake Wheels purchased with brake

- For Brake wheels: see page 9 for wheel data required for order entry)

Brake Wheels

- For spare wheels, supply existing Square D / EC&M / Hubbell part number (located on wheel hub) or see page 9 for wheel data required for order entry

BRAKE WHEEL ORDERING INFORMATION

Brake Wheels for use with Class 5010 Type F, Class 5060 Type AT and Bulletin 4208 Brakes

Dimensions Required for Ordering Wheels:

BASIC WHEEL DIMENSIONS:

D = _____

E = _____

F = _____

BORE DIMENSIONS:

B = _____

T = Bore Taper (Indicate One):

_____ Straight

_____ Tapered 1.25"/Ft.

_____ Tapered 1.219"/Ft.

KEYWAY DIMENSIONS:

X = Width = _____

Y = Depth = _____

Y_{max} = 1/2 X

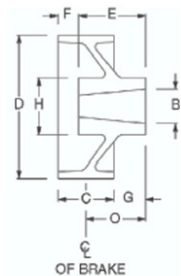

Notes

- For semi-finished wheel (solid hub: no bore or keyway):
 - a. State "Semi-finished wheel is required" on order.
 - b. Supply D, E & F dim. ONLY
- For any set of wheel dimensions $E + F = 1/2C + O$
- Formula for maximum bore: $B_{max} = H - 2(M + Y)$
- Pilot bore = 1"

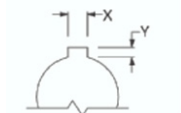

Class 5010 | DC Magnetic Drum Brakes

APPLICATION DATA

Approximate Dimensions—Ductile Iron Brake Wheels
Standard Semi-Finished Wheel Dimension references ▲

Standard Wheel Dimensions Inches (mm) (Consult Factory for Non-Standard Dimensions)							Machining Limitations Inches (mm)		
D	C	E	F	G	H	O	F	O	M*
							Max.	Min.	
8	3.25 (83)	3.0 (76)	2.6 (66)	2.4 (61)	3.25 (83)	4.05 (103)	2.7 (69)	2.6 (66)	0.38 (10)
	3.25 (83)	6.9 (175)	0.2 (5)	3.9 (99)	3.25 (83)	5.55 (141)	2.7 (69)	2.6 (66)	0.38 (10)
	3.25 (83)	5.6 (142)	0.8 (20)	3.1 (79)	3.7 (94)	4.75 (121)	2.6 (66)	2.4 (61)	0.38 (10)
10	3.75 (95)	3.5 (89)	2.6 (66)	2.4 (61)	4.0 (102)	4.25 (108)	3.1 (79)	2.8 (71)	0.50 (13)
	3.75 (95)	6.3 (160)	1.5 (38)	4.0 (102)	4.0 (102)	5.85 (149)	3.1 (79)	2.8 (71)	0.50 (13)
	3.75 (95)	6.0 (152)	1.5 (38)	3.8 (97)	4.7 (119)	5.65 (144)	2.8 (71)	2.5 (64)	0.50 (13)
13	5.75 (146)	4.5 (114)	3.7 (94)	2.5 (64)	5.5 (140)	5.35 (136)	4.5 (114)	3.4 (86)	0.63 (16)
	5.75 (146)	8.6 (218)	0.9 (23)	3.8 (97)	5.5 (140)	6.65 (169)	4.5 (114)	3.4 (86)	0.63 (16)
	5.75 (146)	5.5 (140)	3.0 (76)	2.8 (71)	6.5 (165)	5.65 (144)	4.1 (104)	3.0 (76)	0.63 (16)
16	6.75 (171)	4.5 (114)	5.4 (137)	3.1 (79)	5.5 (140)	6.45 (164)	6.0 (152)	5.4 (137)	0.63 (16)
	6.75 (171)	8.5 (216)	2.9 (74)	4.6 (117)	5.5 (140)	7.95 (202)	6.0 (152)	5.4 (137)	0.63 (16)
	6.75 (171)	5.8 (147)	4.1 (104)	3.1 (79)	6.5 (165)	6.45 (164)	5.4 (137)	4.9 (124)	0.63 (16)
19	8.75 (222)	5.0 (127)	6.9 (175)	3.1 (79)	6.6 (168)	7.45 (189)	7.0 (178)	6.0 (152)	0.75 (19)
	8.75 (222)	7.8 (198)	5.0 (127)	4.0 (102)	6.6 (168)	8.35 (212)	7.0 (178)	6.0 (152)	0.75 (19)
	8.75 (222)	9.3 (236)	3.5 (89)	4.0 (102)	9.0 (229)	8.35 (212)	6.1 (155)	4.9 (124)	0.75 (19)
23	11.25 (286)	6.0 (152)	8.4 (213)	3.1 (79)	8.0 (203)	8.7 (221)	8.8 (224)	6.9 (175)	1.0 (25)
	11.25 (286)	9.2 (234)	5.3 (135)	3.2 (81)	8.0 (203)	8.8 (224)	8.8 (224)	6.9 (175)	1.0 (25)
	11.25 (286)	10.2 (259)	5.4 (137)	4.2 (107)	10.0 (254)	15.6 (396)	8.1 (206)	6.2 (157)	1.0 (25)
30	14.25 (362)	7.3 (185)	10.6 (269)	3.6 (91)	12.5 (318)	10.7 (272)	10.5 (267)	9.4 (239)	1.38 (35)
	14.25 (362)	10.1 (257)	7.8 (198)	3.6 (91)	12.5 (318)	10.7 (272)	10.5 (267)	9.4 (239)	1.38 (35)

▲ An extra charge may be made for special wheels which cannot be machined from the standard semi-finished wheels detailed above. Consult factory for pricing

* Minimum material required over keyway

Replacement Ductile Iron Brake Wheels

AIST Standard

Brake Wheels are designed for use with AIST Brakes, 8" to 30" (wheel diameter in inches)

Ratings Data

Brake Size (Wheel diameter, in inches)	Maximum Torque Ratings (lb-ft)					Adjustment Range with Form H, Half-Torque Spring
	Series Brake		Shunt Brakes			
	½ Hour Rating	1 Hour Rating	1 Hour Rating	8 Hour Rating	Rectifier & High Speed Operated	
8	100	65	100	75	100	35-50
10	200	130	200	150	200	50-100
13	550	365	550	400	550	138-275
16	1000	650	1000	750	1000	250-500
19	2000	1300	2000	1500	2000	500-1000
23	4000	2600	4000	3000	4000	1000-2000
30	9000	6000	9000	6750	9000	N/A

Class 5010 | DC Magnetic Drum Brakes

Weights and Wheel Data

Brake Size (Wheel diameter, in inches)	Approximate Net Weight lbs. (kg)		WR ² of Wheel (lb-ft ²)	Maximum Allowable Speed (RPM)
	Brake Only	Wheel Only		
8	135 (61.2)	17 (7.7)	1	5000
10	205 (93.0)	25 (11.3)	2.7	4000
13	420 (190.5)	60 (27)	10	3300
16	630 (285.8)	110 (50)	30	2800
19	1025 (464.9)	175 (79)	72	2300
23	2100 (952.6)	300 (136)	178	1900
30	3050 (1383.5)	765 (347)	600	1600

BRAKE TORQUE SELECTION

Brake sizes are selected by the amount of brake torque required for the particular application. Generally, the full load torque of the motor is used as a basis for determining the brake torque required. Motor full load torque can be calculated by using the following formula for both AC and DC motors:

$$\text{Torque} = (\text{Rated HP} \times 5252) / (\text{Rated RPM})$$

Depending on the characteristics of the drive, the brake torque required may be more or may be less than the full load torque of the motor. Consult HOIST BRAKE SELECTION and BRIDGE AND TROLLEY BRAKE SELECTION sections below.

Once the required brake torque is determined, choose a brake size from the rating table that has a maximum torque rating of not less than the brake torque required. In addition, if the running speed of the motor is over 600 rpm and the brake service is severe, do not exceed 90% of the maximum rated torque.

The brake torque for most brakes listed can be accurately adjusted down to approximately 50% of their maximum ratings. For applications other than crane hoist drives where the required torque setting is less than 50% of the maximum rating, the brake can be supplied with a 50% torque spring. For this option, consult factory.

HOIST BRAKE SELECTION

AIST Technical Report No. 6, CMAA Specification No. 70, and OSHA Regulations state that the hoist brake is to be selected based on the torque required to hoist rated crane load at the point where the brake is applied.

All three standards require that a hoist drive handling hot metal be equipped with more than one brake. ♦

	Basis for Selection of Brake Torque	Brake Torque Rating			
		Hoist Drive with Single Brake		Hoist Drive with Two or More Brakes ♦	
		With Control Braking ■	With Mechanical Load Brake	Handling Hot Metal	Not Handling Hot Metal
CMAA	Torque Required to Hoist Rated Load	125%	100%	100%	100%
OSHA		125%	100%	100%	100%
AIST		150%	150%	125%	100%

■ Control braking is dynamic braking, dynamic lowering, countertorque or eddy current load brake

♦ Failure of any one brake will not cause the remaining torque to fall below levels shown

Class 5010 | DC Magnetic Drum Brakes

BRIDGE AND TROLLEY BRAKE SELECTION

The three standards provide guidelines for the application of brakes to bridge and trolley drives.

Application	Interpretation	Recommendation
Cab-Operated Cranes with the cab located on the Bridge	<p>Bridge A bridge brake of the stopping or holding type is required.</p> <p>Trolley A trolley brake of the stopping or holding type is required.</p>	<p>OSHA defines a brake as “a device used for retarding or stopping motion by friction or power means”.</p> <p>“A drag brake is a brake which provides retarding force without external control”.</p>
Cab-Operated Cranes with the cab located on the Trolley	<p>Bridge A bridge brake of the holding type is required.</p> <p>Trolley A trolley brake of the stopping or holding type is required.</p>	<p>“A holding brake is a brake that automatically prevents motion when power is off”.</p>
Floor, Remote and Pulpit-Operated Cranes	<p>Bridge A bridge brake of the stopping or holding type or non-coasting mechanical bridge drive is required.</p> <p>Trolley A trolley brake is not required but one may be used to eliminate creep with the power off.</p>	<p>AIST and OSHA specify that stopping brakes be selected to (1) stop the drive within a distance in feet equal to ten percent of full load speed in feet per minute when traveling at full speed with full load. (2) stop the drive from full load free running speed to zero speed at a deceleration rate equal to the acceleration rate for the drive.</p>

Application	Brake Torque Rating ●			
	Bridge		Trolley	
	AIST	CMAA	AIST	CMAA
Cab-operated cranes with the cab located on the bridge	See Below	100%	50%	50%
Cab-operated cranes with the cab located on the trolley	100%	75%	--	100%
Floor, Remote, and Pulpit-operated cranes	100%	50%	50%	50%

● Ratings are based on motor full load torque

OSHA does not specify brake torque rating in percent of motor full load torque for bridge and trolley drives. Usually the limiting factor for selection of the brake size is the thermal capability of the brake wheel for the frequency of operation required by the service. Similarly, for cab-operated cranes with the cab located on the bridge, AIST requires a brake of the stopping type for the bridge. The brake must be capable of stopping the bridge from full speed in a distance in feet not greater than 10% of the full load speed in fpm. Also the thermal capacity must be adequate for the duty. For cab-operated cranes with the cab located on the trolley, AIST requires a brake of the stopping type for the trolley. It must be sized similar to the bridge brake.

Brake Selection - Thermal Capability

In addition to being selected to meet the torque requirements of the particular application, the brake used for stopping must be selected to prevent overheating of the brake wheel when operated on the anticipated duty cycle.

To calculate how often a stop can be made from full speed without overheating the brake wheel:

$$\frac{(k) \times (CWL) \times (SL)^2}{(B) \times (M)} = \text{Seconds}$$

(M) = Number of motors

(B) = Number of brakes per motor

CWU = Crane weight (tons)

CL = Crane Load (tons)

CWL = Crane weight loaded (tons) = (CWU + CL)

(SU) = Free-running speed unloaded (FPM)

(SL) = Free-running speed loaded (FPM)

(kl) = Constant (see table)

A stop can be made from full speed this often without overheating the brake wheel.

Four times as many stops can be made from half speed in this time interval. For unloaded crane conditions (CWL) and (SL) are replaced by (CWU) and (SU).

Brake Size (Wheel diameter, in inches)	(kl)
8	26.50 x 10 ⁻⁶
10	15.90 x 10 ⁻⁶
13	9.34 x 10 ⁻⁶
16	6.10 x 10 ⁻⁶
19	4.30 x 10 ⁻⁶
23	3.00 x 10 ⁻⁶
30	1.76 x 10 ⁻⁶

Class 5010 | DC Magnetic Drum Brakes

APPLICATION DATA

Elementary Wiring Diagrams for Standard Brake Circuits

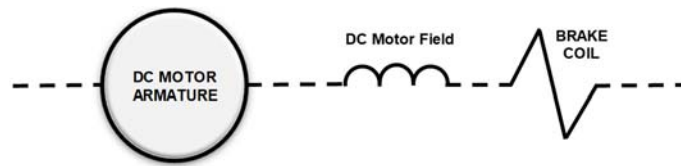

DC Series Brake: (DC Hoist or Travel Motions)

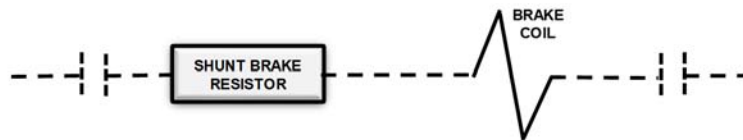

DC Standard Shunt Brake: (DC Travel Motions Only)

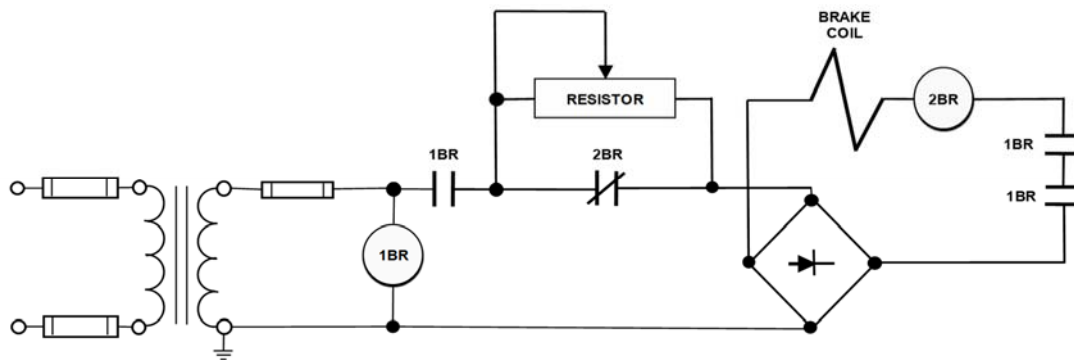

AC Rectifier Operated Brake, Type QW Brake Rectifier Controller

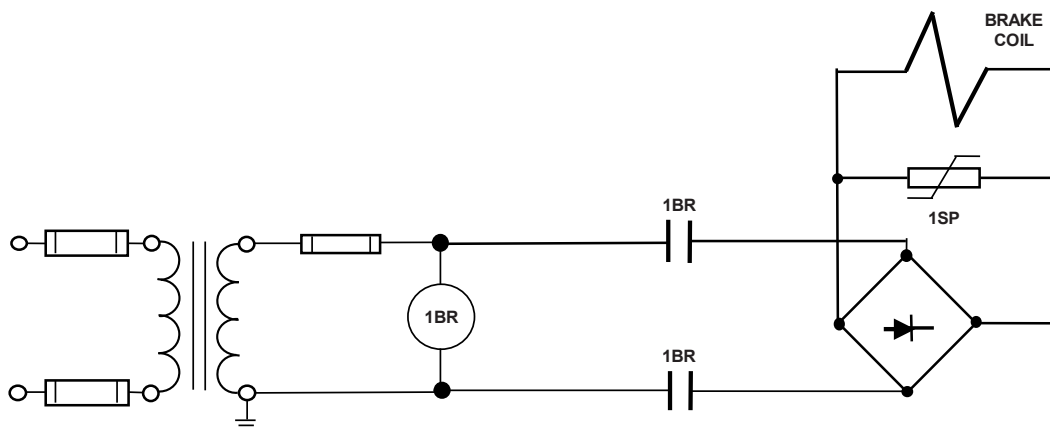

AC Rectifier Operated Brake, Type LC Brake Rectifier

Class 5010 | DC Magnetic Drum Brakes

APPROXIMATE DIMENSIONS

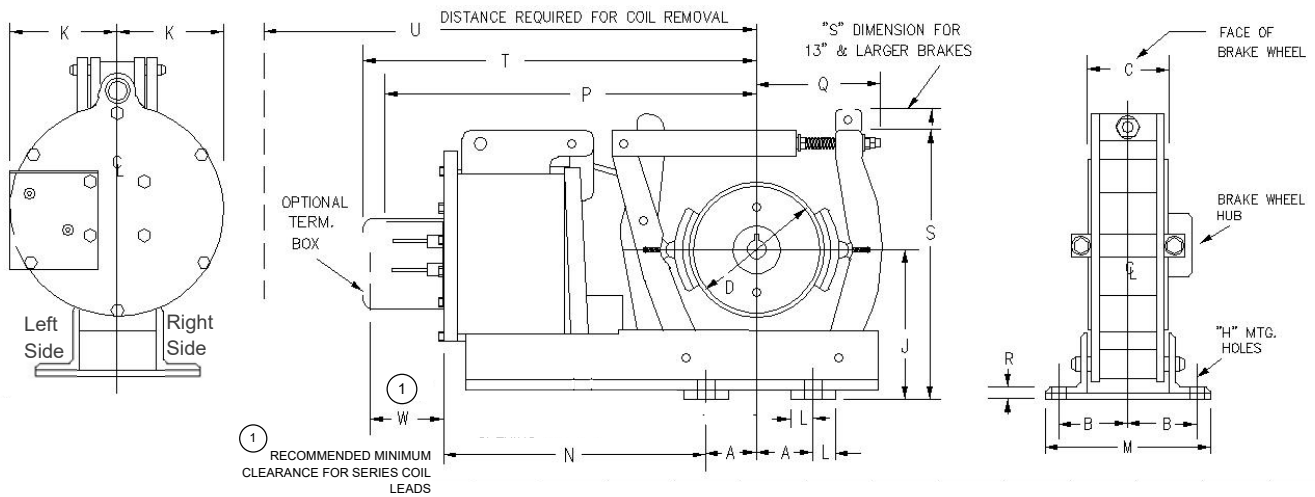

8-Inch Through 23-Inch Brakes

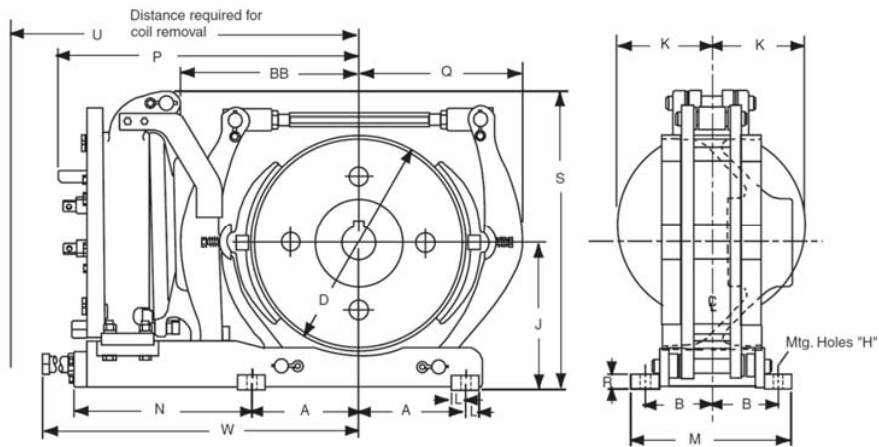

30-Inch Brakes

Brake Size	A	B	D	H	J	K	L	M	N	P	Q	R	S	T	U	W
8	3.25 83	2.87 73	8.00 203	.69 17	7.00 178	4.75 121	.875 22	7.56 192	11.30 287	17.65 448	7.25 184	.56 14	13.81 351	17.75 451	24.0 610	3.5 89
10	4.00 102	3.12 79	10.00 254	.69 17	8.37 213	5.50 140	1.00 25	7.88 200	14.12 359	20.72 526	8.42 219	.63 16	16.20 411	22.84 580	28.8 732	3.5 89
13	5.75 146	4.50 114	13.00 330	.81 21	9.88 251	7.00 178	1.00 25	10.50 267	15.25 387	23.6 599	11.25 286	.91 23	20.00 508	26.85 682	32.9 836	4.0 102
16	7.50 191	5.37 137	16.00 406	1.06 27	12.12 308	8.00 203	1.50 38	13.00 330	17.06 433	27.16 690	12.96 329	1.25 32	25.50 648	30.4 772	36.4 925	4.5 114
19	9.25 235	6.50 165	19.00 483	1.06 27	13.25 337	9.25 235	1.75 44	16.50 419	20.06 510	33.25 845	16.50 419	1.12 28	28.50 724	36.54 928	44.4 1128	4.5 114
23	11.75 298	8.00 203	23.00 584	1.31 33	15.87 403	11.00 279	1.25 32	19.00 483	19.25 489	35.1 892	19.50 495	1.25 32	34.87 886	38.2 970	42.0 1067	5.0 127
30	15.00 381	9.50 241	30.00 762	1.56 40	20.75 527	13.38 340	2.00 51	23.00 584	25.00 635	41.9 1064	23.5 597	2.00 51	42.5 1207	47.0 1194	47.5 1206	Consult Factory

Dual Dimensions: $\frac{\text{In}}{\text{mm}}$

Class 5010 | DC Magnetic Drum Brakes
APPROXIMATE DIMENSIONS AND WEIGHTS

Dual Dimensions: $\frac{\text{In}}{\text{mm}}$

BRAKE RECTIFIER CONTROLLERS

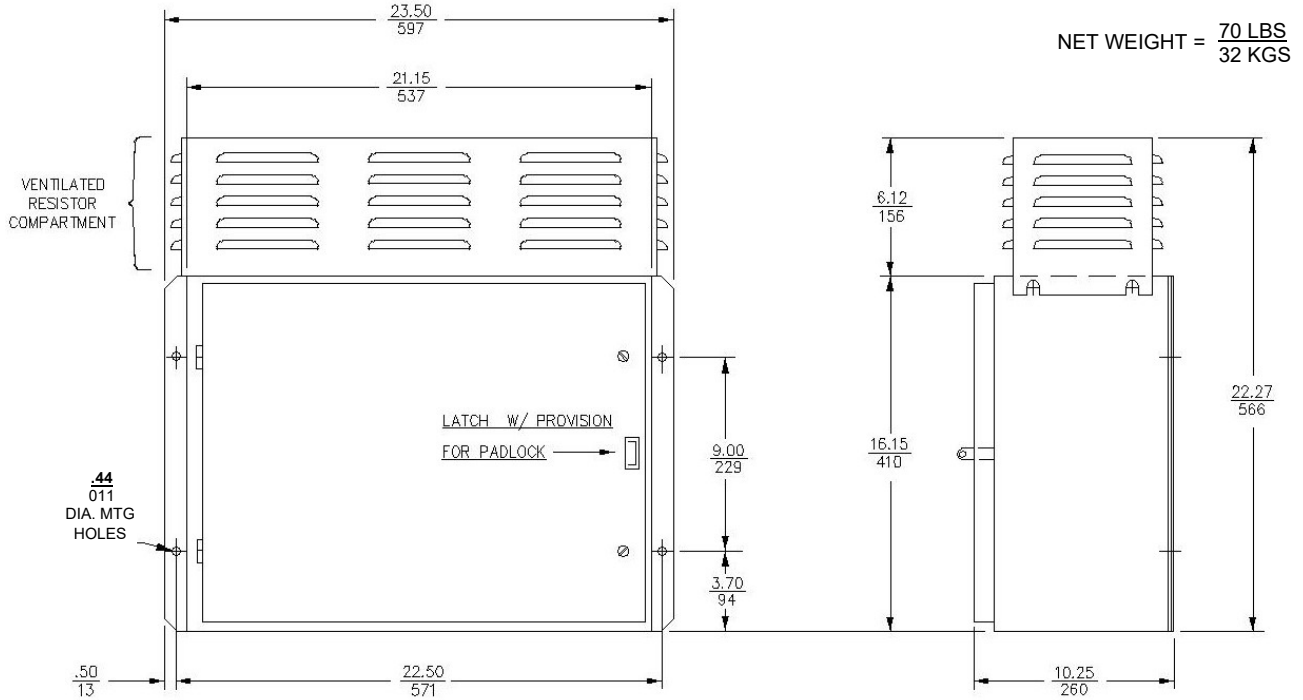

Types QW108 through QW130, QW208 through QW223

BRAKE RECTIFIER

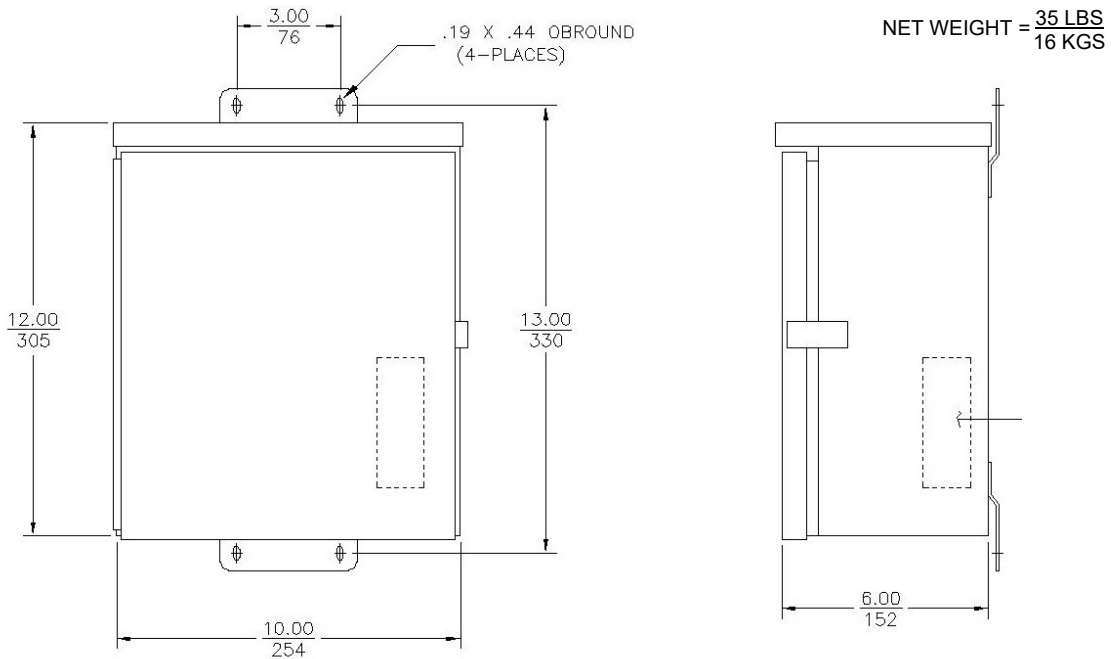

Types LC108, LC110, LC113, LC208, LC210



hubbell.com

©2022 Hubbell Harsh & Heavy Industry. All rights reserved.

Hubbell, the Hubbell logo are registered trademarks or trademarks of Hubbell Harsh & Heavy Industry.

All other trademarks are the property of their respective owners.

Printed in U.S.A. | HHI_ECM_BR_EN_00109