

Hubbell Industrial Controls, Inc.

Type 720 200 Ampere 600 Volt DC Contactor

42720

Catalog 42720 • September 2013, Replaces March 2013

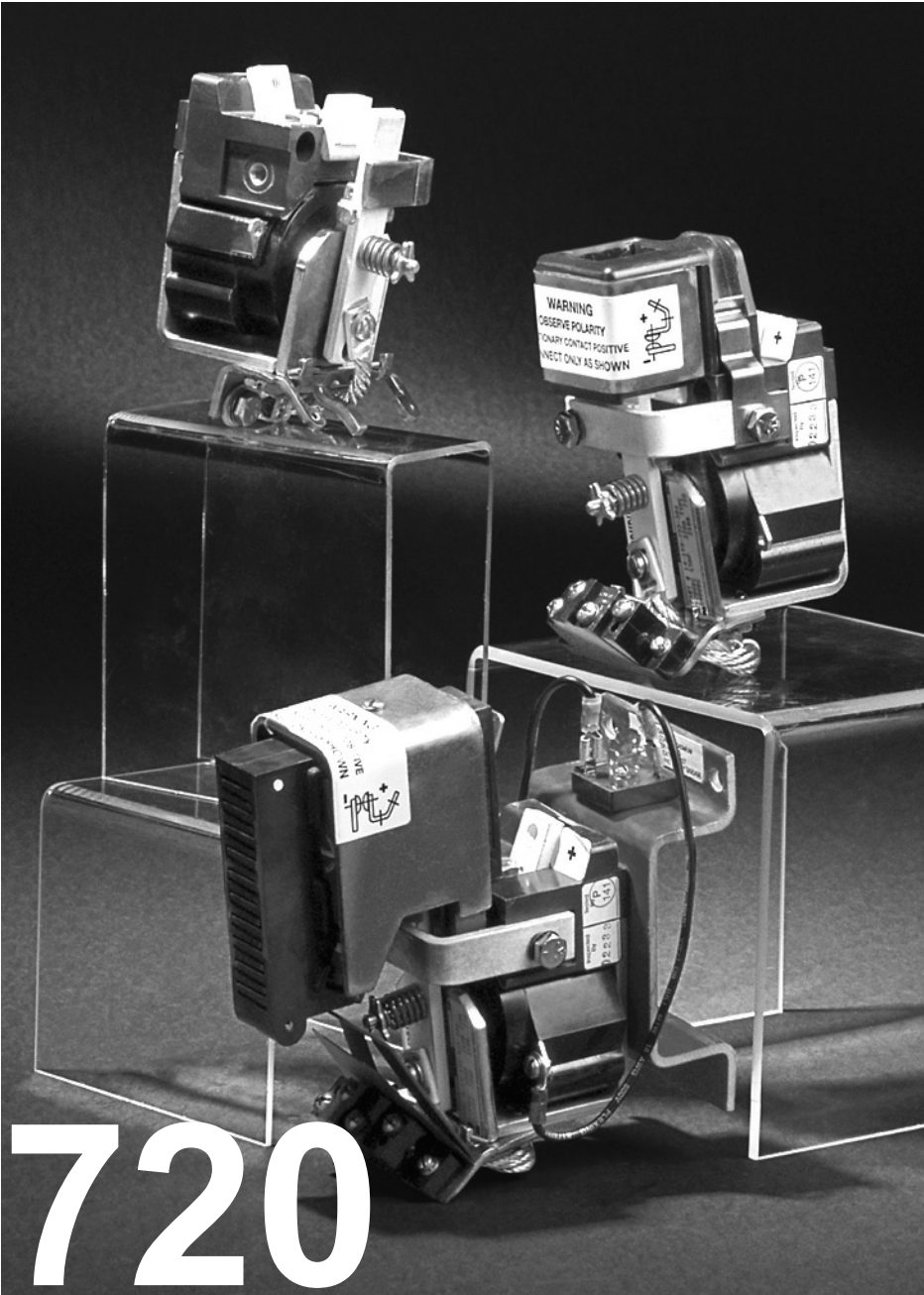

Highlights

- NEMA Size 4 1/2
- UL recognized/CSA certified
- Polarized arc chutes – standard capacity or high capacity
- Main contact options: SPNO, SPDT, Series Field Reverser
- Five million mechanical operations
- Silver alloy main contacts
- Front access for serviceability
- AC or DC operation
- High dielectric and mechanical strength
- Special ratings available – Consult factory

Rugged and reliable, this industrial quality device is used in applications such as gas/oil drilling and solid-state adjustable speed drives, uninterruptible power supplies, fuel cells, crane controls, transit and rail, and mining machinery. It is rated at 200 Ampere, continuous at 600 VDC in still air (special voltages available – consult factory) and can achieve a maximum interrupting rating of 600 kW.

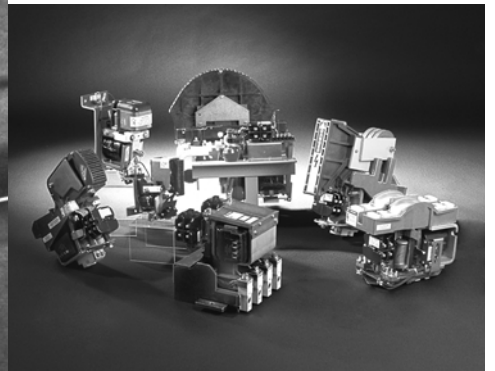

DC CONTACTOR

Amazingly Reliable – Hubbell Industrial Controls Devices

The Hubbell ICD family of rugged, high-performance DC devices are in great demand by industries needing reliable, solid state, adjustable controls. Products include contactors, limit switches, crane controls, fire pump controls, transfer switches, motor controllers and resistors. Hubbell ICD has a device ideal for a wide range of applications. And if it's from Hubbell, you know you're getting amazingly reliable technology.



hubbell industrial controls, inc.

Both UL recognized as a general-purpose NEMA Size 4.5 contactor and UL recognized and CSA certified as a definite purpose contactor for solid-state adjustable speed drives.

Available with SPNO, SPDT, or Series Field Reverser main pole configurations, the Type 720 contactor can be ordered with or without permanent magnet arc chutes. The Type 720 with arc chute is polarized for arc interruption; therefore, external power connections must observe proper polarity, as marked on the power connection terminals, to provide appropriate arc interruption.

When used, the permanent-magnet-type arc chute provides full interrupting capability on the normally open contacts only. When using contactors with normally closed power poles (SPDT and reverser), the application should be reviewed to ensure that the make-and-break capabilities of the normally closed contacts are not exceeded.

Available in ratings from 12 VDC to 250 VDC, the molded coils are Class F (155C) design and rated for continuous duty. Although screw terminals are standard, some coil ratings are available with leads by special order. AC coil operation is achieved by the addition of a full-wave bridge rectifier.

Pilot-duty auxiliary contact blocks are available in 1NO&1NC and 2NO&2NC configurations.

Vertical mounting is recommended for the Type 720 contactor (contact factory for non-vertical mounting considerations). Each device is provided with either an insulated mounting sheet (sheet mounted) or an insulated mounting base (base mounted) for mounting on conductive surfaces. The insulated mounting base provides a location for mounting a full-wave bridge rectifier for AC operation. All terminals and mounting holes are front-accessible for ease of mounting and wiring with hardware provided for these purposes. Front-accessible arc chutes can be easily removed/replaced without tools.

Generously sized silver alloy contact surfaces, inherent wiping action upon closure, silver-plated copper conductors, and high contact pressure assure reliable, robust service from this compact device in the most extreme and demanding environments. Non-conducting steel components are zinc-dichromate plated for corrosion resistance, while the molded components are fabricated from a non-tracking material offering high dielectric strength and protection for the coil from dirt, moisture, and physical abuse.

Product Listing

Special Purpose – Type 720 Series

Ordering Information

- Type 720 contactors are ordered by Catalogue Number as follows: Catalogue Number

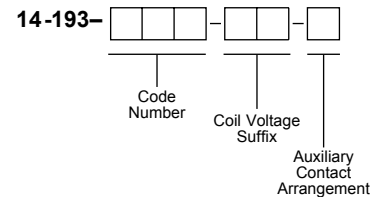

Coil Suffix Table^①

DC Volts Coil Voltage	Suffix
12	51
24	52
36	55
48	54
74	56
96	57
125	58
250	59

Specifications

Type 720, 1A, 1B 200 Amps only

Contactors Configuration

- Single pole, normally open (SPNO)
- Single pole, double throw (SPDT)
- Series field reverser (2 SPDT bussed together)
- Special combinations are available
- Consult Factory

Voltage Rating

- 600 VDC standard
- Consult Factory for special ratings
- UL Recognition File: E79773
- CSA Certification File: LR91674

Mechanical Life

- 5 million operations

Connection

- Power terminals – One ¼–20 tapped hole per terminal
- Coil terminals – Two 8–32 tapped holes
- Full-wave bridge rectifier – Four ¼ in. fastons

Weights

- Contactors without Arc Chute 3.0 lbs. (1.36 kg)
- Contactors with Standard Capacity Arc Chute 3.7 lbs. (1.68 kg)
- Contactors with High Capacity Arc Chute (200 Amp) 4.7 lbs. (2.14 kg)
- Two Contactors with Standard Capacity Arc Chutes 8.2 lbs. (3.72 kg)
- Two Contactors with High Capacity Arc Chutes 10.2 lbs. (4.63 kg)

Mounting

- Two 10–32 screws through contactor and insulation sheet
- Three ¼–20 screws through mounting base



Mounting Hardware

- Two 10–32 screws (contactor)
- Three ¼–20 screws (base)

Main Contact Rating (200 Amps Version)

Description	Normally Open	Normally Closed
Continuous Carry Current Convection Cooled	220 Amps	200 Amps
Maximum Make Rating	2000, 600 V DC	200 Amps, 50 V DC 150 Amps, 150 V DC 100 Amps, 500 V DC
Max Break Rating*	Without Arc Chute	2000, 48 V DC
	With Standard Capacity Chute	300, 300 V DC
	With High Capacity Chute	1200, 125 V DC
	With High Capacity Chute	2000, 300 V DC
	1000, 600 V DC	200 Amps, 50 V DC 150 Amps, 150 V DC 100 Amps, 240 V DC 125 Amps, 125 V DC

Arc chute is permanent magnet type. Polarities must be observed.

CONTACTOR	POWER CIRCUIT DC VOLTAGE	ARC CHUTE	MOUNTING	COIL RECTIFIER	ARC CHUTE POLARITY ²	SPNO CODE	SPDT CODE	REVERSER CODE ^{3,4}
 720, 100 Ampere Without Arc Chute	12 - 48	None	Sheet ⁵	No	N/A	791	792	793
		Std. Capacity	Sheet ⁵	No	Pos.	794	795	796
	50 - 300	Std. Capacity	Sheet ⁵	No	Neg.	798	797	799
		Std. Capacity	Base	Yes	Pos.	771	772	773
		Std. Capacity	Base	Yes	Neg.	774	775	776
 720, 200 Ampere Without Arc Chute	12 - 48	None	Sheet ⁵	No	N/A	751	752	753
		Std. Capacity	Sheet ⁵	No	Pos.	754	755	756
	50 - 300	Std. Capacity	Sheet ⁵	No	Neg.	758	757	759
		Std. Capacity	Base	Yes	Pos.	761	762	769
		Std. Capacity	Base	Yes	Neg.	764	765	766
		High Capacity	Base	No	Pos.	821	822	823
		High Capacity	Base	No	Neg.	831	832	833
		High Capacity	Base	Yes	Pos.	824	825	826
	100 - 600	High Capacity	Base	Yes	Neg.	834	835	836
		High Capacity	Sheet ⁵	No	Pos.	841	842	843
		High Capacity	Sheet ⁵	No	Neg.	851	852	853
		High Capacity	Sheet ⁵	No	Neg.	851	852	853

AUXILIARY CONTACTS³

CONFIGURATION	CODE
1 NO & 1 NC	6
2 NO & 2 NC	2
None	7

¹ For 120 volts, 60 Hz operation, use 125 volt DC coil with full-wave bridge rectifier.

² For maximum break rating of polarity sensitive arc chutes, connect indicated polarity to normally open stationary terminal.

³ For reversers, price two auxiliary contacts: (1) for forward, (1) for reverse.

⁴ Configured for series field reversal.

⁵ Insulated mounting sheet (1/32" thick) provided with contactor.

⁶ Coil voltage tolerance 85 to 100% of rated voltage.

Connection Diagrams

Operating Coils

Volts DC	Ohms (20°C)	Volts DC	Ohms (20°C)
12	2.6	74	93
24	10.4	96	148
36	25	125	226
48	41.1	250	960

Minimum pickup voltage is 55% of rated coil volts, with cold coil and 80% of rated coil volts with hot (140°) coil. Dropout is from 5% to 25% of rated coil volts. Coil overvoltage tolerance is 10%.

Auxiliary Contacts

Configuration	Continuous Current	Make and Break
1 NO and 1 NC	15 Amps**	15 Amps, 600 V AC, resistive 0.4 Amps, 115 V DC, inductive 0.2 Amps, 230 V DC, inductive
2 NO and 2 NC	10 Amps**	10 Amps, 600 V AC, resistive 0.2 Amps, 115 V DC, inductive 0.1 Amps, 230 V DC, inductive

* Resistive load – consult sales office for inductive load break ratings. For arc chute spacings to ground, consult sales office.

** Each normally open and normally closed pair must be wired to the same side of the same supply (same polarity).

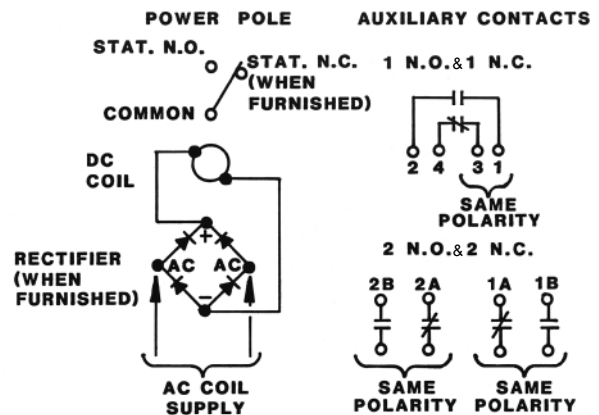

DC Contactor Type 720 Replacement Parts:

Coils, DC

Type	Coil Voltage	Catalog No.
720	12V	14-183-211-503
	24V	14-183-212-503
	36V	14-183-213-503
	48V	14-183-217-503
	74V	14-183-328-503
	96V	14-183-312-503
	125V	14-183-319-503
	250V	14-183-320-503

Main Contacts

Type	Size	Contact Type	Catalog No.
720	100A	SPNO	14-192-888-801
		SPDT	14-192-888-802
		REV	14-192-888-803
	200A	SPNO	14-192-887-801
		SPDT	14-192-887-802
		REV	14-192-887-803

Auxiliary Contact Blocks

Type	Size	Arrangement		Catalog No.
		NO	NC	
720	100A	1	1	14-232-550-013
		2	2	00-871-383-404
	200A	1	1	14-232-550-013
		2	2	00-871-383-404

Arc Chutes

Type	Size	Polarity/ Capacity	Catalog No.
720	100A	STAT+	14-178-819-501
		STAT-	14-192-542-501
	200A	STAT+/std.	14-178-819-501
		STAT-/std.	14-192-542-501
		STAT+/high	14-192-852-501
		STAT-/high	14-192-852-502

Outline Drawings

Special Purpose – Type 720

Type 720, Contactor with Standard Capacity Arc Chute, Insulated Sheet and Base Mounted

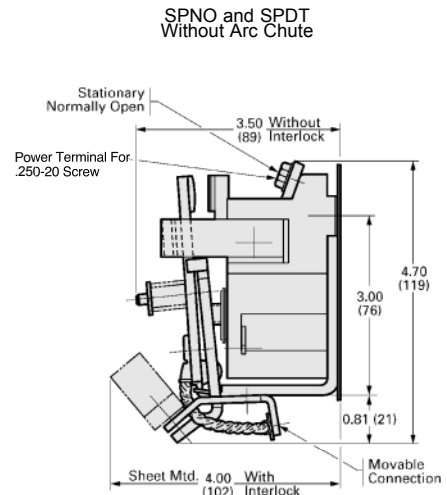
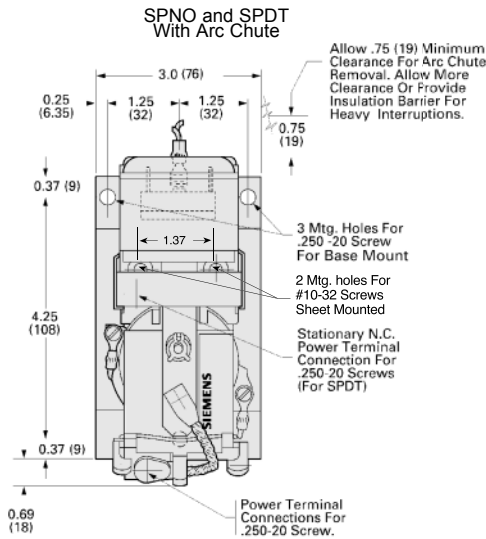

Reverser

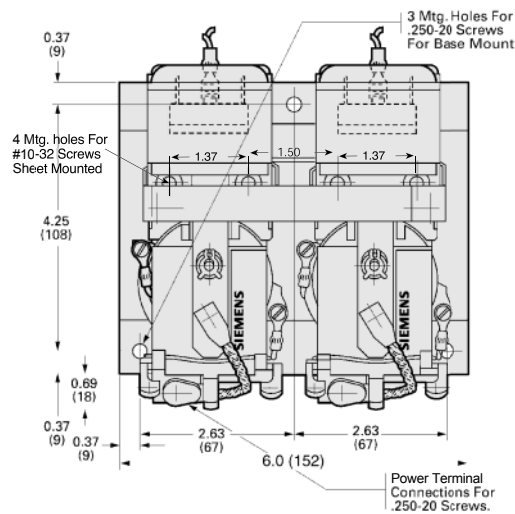

Side View

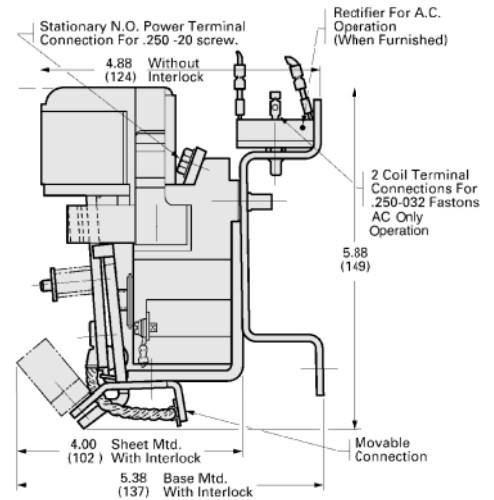

Type 720, Contactor with High Capacity Arc Chute, Insulated Sheet and Base Mounted

SPNO and SPDT

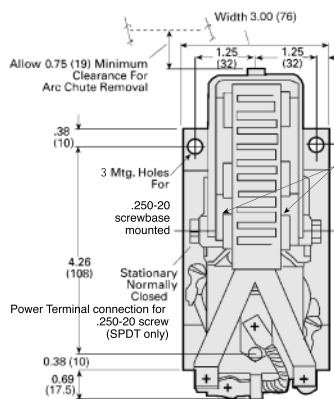

Reverser

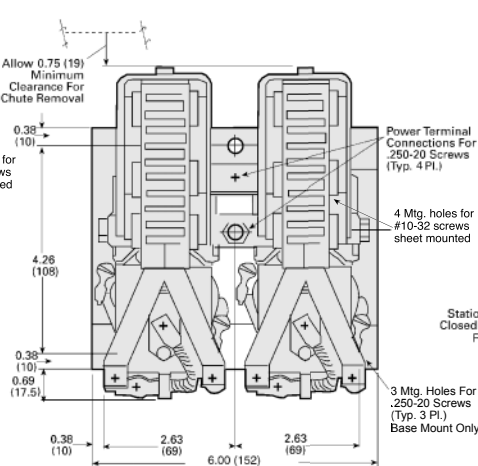

Side View

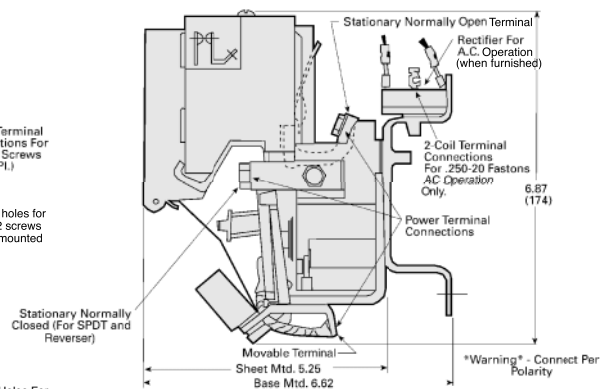

All dimensions shown in inches. For reference purposes only. Not to be used for design or construction purposes.

Hubbell Industrial Controls, Inc.

A subsidiary of Hubbell Incorporated

4301 Cheyenne Dr., Archdale, NC 27262

Telephone (336) 434-2800 • Fax (336) 434-2803

<http://www.hubbell-icd.com>

Sales@hubbell-icd.com

