



Replacement Parts

53-GC1188

November 2003

Master Switch
C1188
Class 53

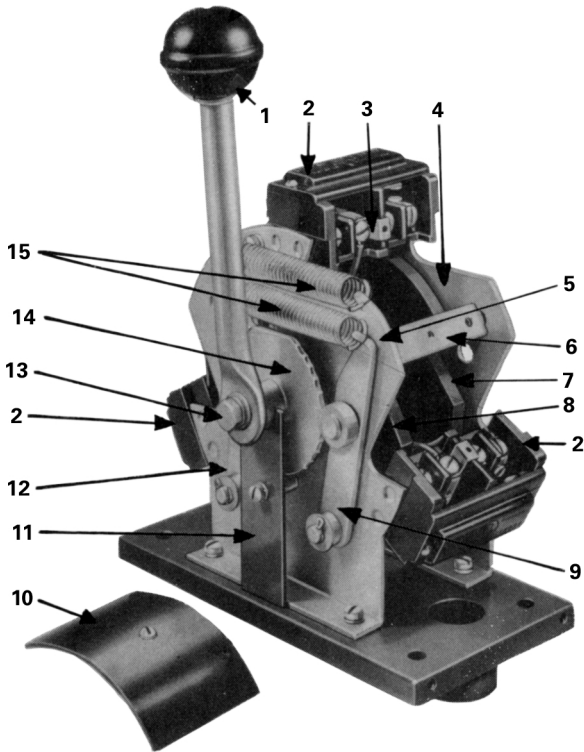

Item	# Reqd.	Part No.	Description
1	1	D07120001	Complete Handle Assembly
		D26842001	Handle Knob Only
2	3	D72145008	Contact Board Assembly
3	1	D00684003	Jumper
4	1	D07192001	Frame Plate Assembly (Rear)
5	1	D09961003	Frame Plate Assembly (Front)
6	2	D07143001	Stiffening Bars
7	1	D01900005	Bakelite Cam
8	1	D01900006	Bakelite Cam
9	1	D07121002	Lever Assembly
10	2	D07144001	Shields
11	1	D07134001	Slot Cover
12	1	D10557001	Lever Assembly
13	1	S00195003	Cap Screw Hex., 1/4-20x1/2"
14	2	D07614001	Indexing Cam
15	2	D07164002	Indexing Spring

Pilot Circuit Rating
10 Amps. 120-140 V. AC
5 Amps 480-660 V. AVC

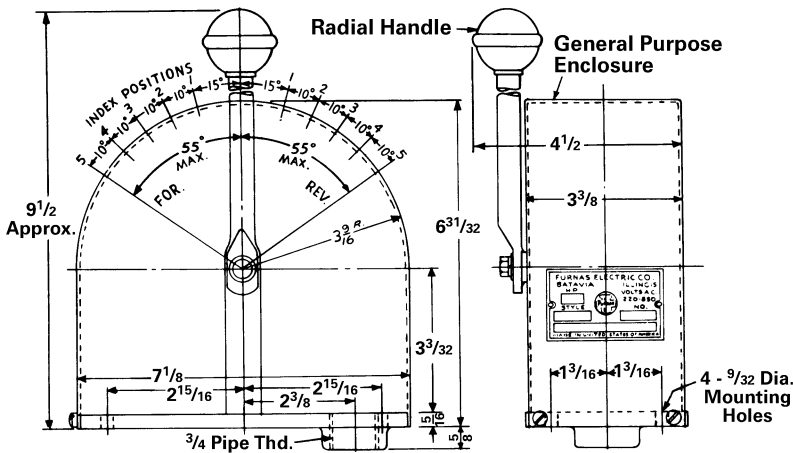

Ref. D1794

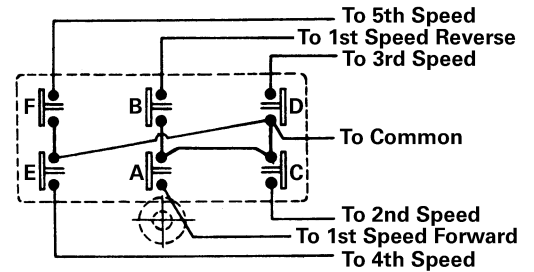

Forward		Reverse	
Speed	Contacts Closed	Speed	Contact Closed
1	A	1	B
2	A-C	2	B-C
3	A-C-D	3	B-C-D
4	A-C-D-E	4	B-C-D-E
5	A-C-D-E-F	5	B-C-D-E-F

Ref. D1745

(For Engineering Reference Only - Rev. B)